

HORIZON SERIES

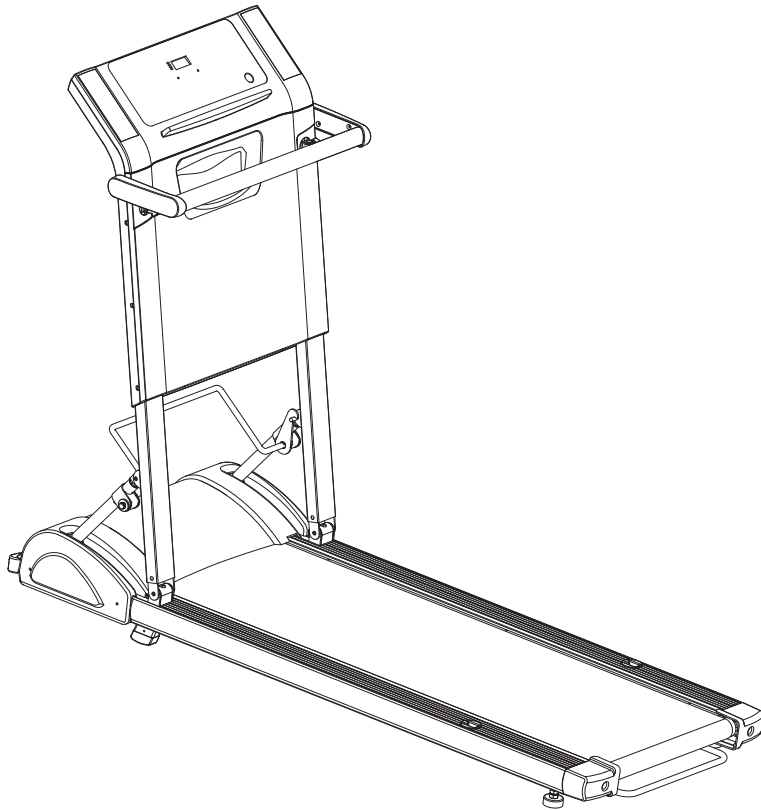

FOR MODEL :

EVOLVE
SIMPLE STEPS



HORIZON
FITNESS

TREADMILL USER'S GUIDE

INTRODUCTION

CONGRATULATIONS on choosing your treadmill! You've taken an important step in developing and sustaining an exercise program! Your treadmill is a tremendously effective tool for achieving your personal fitness goals. Regular use of your treadmill can improve the quality of your life in so many ways.

Whether your goal is to win races or simply enjoy a fuller, healthier lifestyle, a Horizon Fitness treadmill can help you attain it – adding quality performance to your at-home workouts, with the ergonomics and innovative features you need to get stronger and healthier, faster. Because we're committed to designing fitness equipment from the inside out, we use only quality components.

You want exercise equipment that offers the most comfort, the best reliability and quality in its class.

Horizon Fitness delivers.

TABLE OF CONTENTS

<i>Important Precautions</i>	<i>4</i>
<i>About Your Treadmill</i>	<i>6</i>
<i>Before You Begin</i>	<i>10</i>
<i>Treadmill Operation</i>	<i>13</i>
<i>Conditioning Guidelines</i>	<i>20</i>
<i>Troubleshooting & Maintenance</i>	<i>24</i>
<i>Limited Warranty</i>	<i>27</i>
CONTACT INFORMATION	<i>Back Panel</i>

IMPORTANT PRECAUTIONS

SAVE THESE INSTRUCTIONS

Read all instructions before using this treadmill. When using an electrical product, basic precautions should always be followed, including the following: Read all instructions before using this treadmill. It is the responsibility of the owner to ensure that all users of this treadmill are adequately informed of all warnings and precautions. If you have any questions after reading this manual, contact Customer Tech Support at the number listed on the back panel of this manual.



Connect this exercise product to a properly grounded outlet only. See grounding instructions.

GROUNDING INSTRUCTIONS

This product must be grounded. If a treadmill should malfunction or breakdown, grounding provides a path of least resistance for electrical current to reduce the risk of electrical shock. This product is equipped with a cord having an equipment-grounding conductor and a grounding plug. The plug must be plugged into an appropriate outlet that is properly installed and grounded in accordance with local codes and ordinances.



Improper connection of the equipment-grounding conductor can result in a risk of electric shock. Check with a qualified electrician or serviceman if you are in doubt as to whether the product is properly grounded. Do not modify the plug provided with the product. If it will not fit the outlet, have a proper outlet installed by a qualified electrician.

This product is for use on a nominal 110-volt circuit and has a grounding plug that looks like the illustration. This product must be used on a dedicated circuit. To determine if you are on a dedicated circuit, shut off the power to that circuit and observe if any other devices lose power. If so, move devices to a different circuit. **NOTE:** There are usually multiple outlets on one circuit. It is recommended that the treadmill be used with a 15 amp circuit for optimal performance.

3-Pole Grounded Outlet

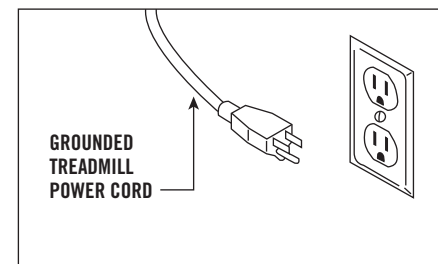

At NO time should pets or children under the age of 12 be closer to the treadmill than 10 feet. At NO time should children under the age of 12 use the treadmill. Children over the age of 12 should not use the treadmill without adult supervision.



WARNING To reduce the risk of burns, fire, electrical shock or injury to persons:

- Never use the treadmill before securing the safety tether clip to your clothing.
- If you experience any kind of pain, including but not limited to chest pains, nausea, dizziness, or shortness of breath, stop exercising immediately and consult your physician before continuing.
- Do not wear clothes that might catch on any part of the treadmill.
- Always wear athletic shoes while using this equipment.
- Do not jump on the treadmill.
- Keep power cord away from heated surfaces.
- Do not insert or drop any object into any opening.
- Unplug treadmill before moving or cleaning it. To clean, wipe surfaces down with soap and slightly damp cloth only; never use solvents. (See MAINTENANCE)
- At no time should more than one person be on treadmill while in operation.
- The treadmill should not be used by persons weighing more than 114 kg (250 lbs). Failure to comply will void the warranty.
- The treadmill is intended for in-home use only. Do not use this treadmill in any commercial, rental, school or institutional setting. Failure to comply will void the warranty.
- Do not use treadmill in any location that is not temperature controlled such as but not limited to garages, porches, pool rooms, bathrooms, car ports or outdoors. Failure to comply may void the warranty.
- Use the treadmill only as described in this manual.

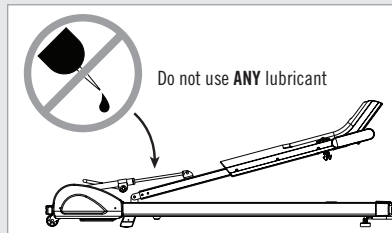

CAUTION

Do not apply ANY lubricant to the folding mechanism. This could damage it. Failure to comply may void the warranty.

OTHER SAFETY TIPS FOR YOUR TREADMILL



OPERATION

To reduce the risk of damaging important components on your treadmill, it is strongly recommended that your treadmill is plugged into a dedicated 15 amp circuit, without the use of an additional extension cord and/or power strip. Failure to comply may void the warranty.

IMPORTANT: The treadmill is not compatible with GFCI-equipped outlets.

It is essential that your treadmill is used only indoors, in a climate-controlled room. If your treadmill has been exposed to colder temperatures or high moisture climates, it is strongly recommended that the treadmill is warmed up to room temperature before first time use. Failure to do so may cause premature electronic failure.

ABOUT YOUR TREADMILL

THERE IS NO ASSEMBLY REQUIRED FOR THIS TREADMILL!

UNPACKING

Place the treadmill carton on a level flat surface. It is recommended that you place a protective covering on your floor. Take CAUTION when handling and transporting this unit. Never open box when it is on its side. Unpack the unit where it will be used. FAILURE TO FOLLOW THESE INSTRUCTIONS COULD RESULT IN INJURY!

Before proceeding, find your treadmill's serial number and model name located on the stabilizer leg and enter it in the space provided below.

ENTER YOUR SERIAL NUMBER AND MODEL NAME IN THE BOXES BELOW:

SERIAL NUMBER:

MODEL NAME:

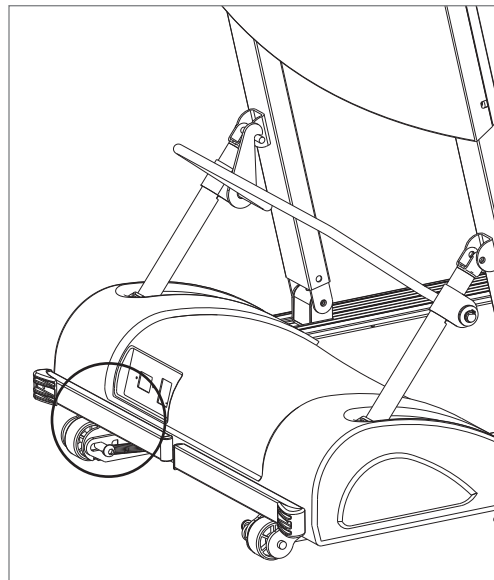

* Refer to the SERIAL NUMBER and MODEL NAME when calling for service.

* Also enter this serial number on your Warranty Card.

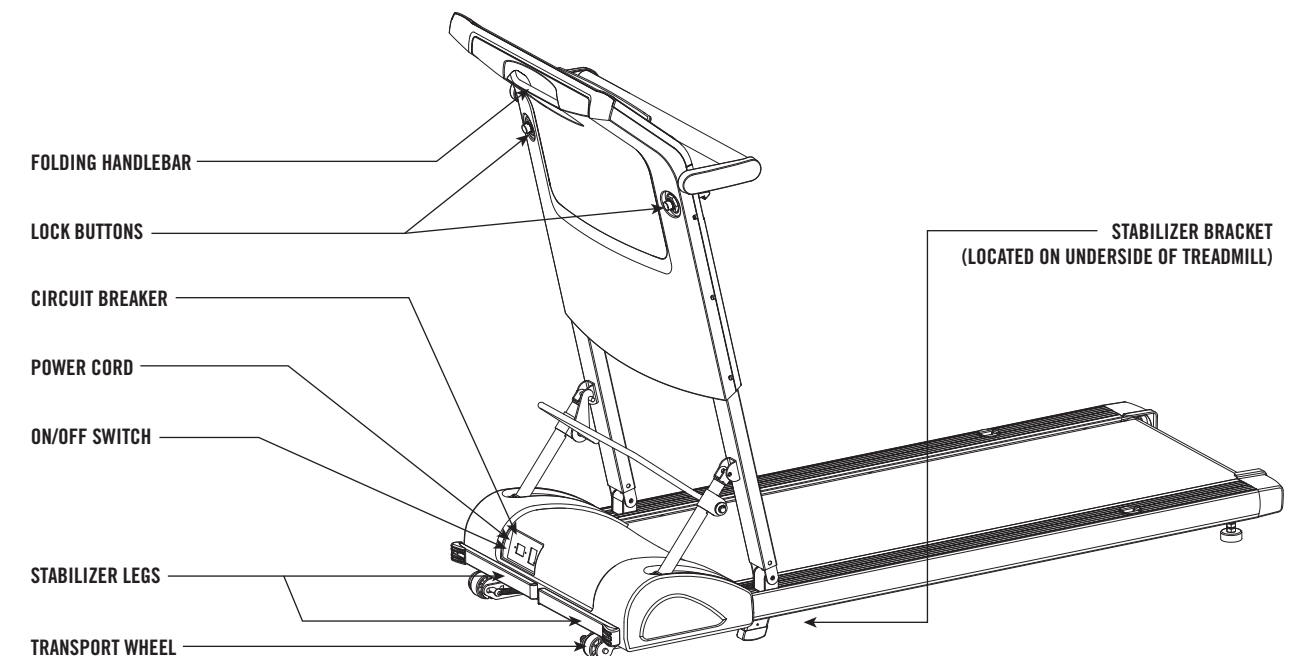
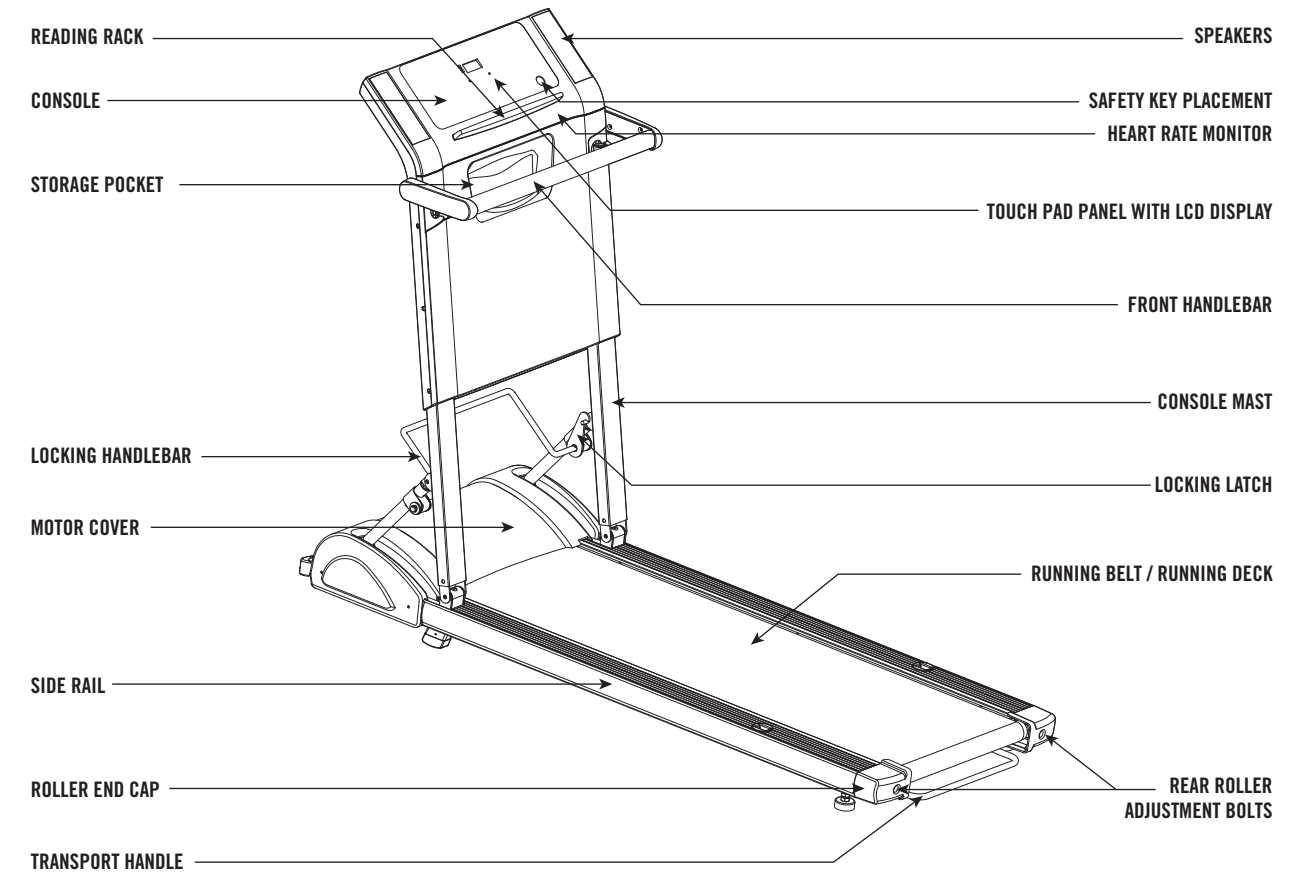

UNFOLDING

The treadmill was folded in the carton when purchased. Follow these steps to unfold the treadmill.

1. Press and hold both **LOCK BUTTONS** with your thumbs.
2. Carefully lift the **CONSOLE MODULE** upward until it is in the upright position.
3. Pull the **LOCKING BAR** upward until it is tight.
4. Gently pull the **FRONT HANDLEBAR** downward.

CAUTION:

Do not use the treadmill if the **LOCKING BAR** is not tight.

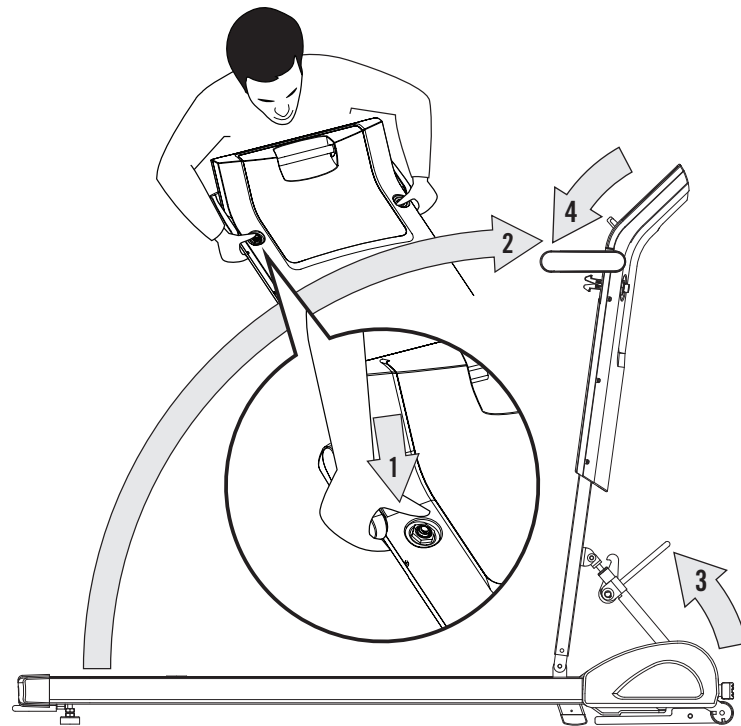

FOLDING

Follow these steps to fold the treadmill.

1. Gently pull the **FRONT HANDLEBAR** upward.
2. Pull the **LOCKING BAR** downward to release the lock.
3. Carefully pull the **CONSOLE MODULE** downward until it rests flat on the treadmill deck.
4. Press down on the **CONSOLE MODULE** until both locks engage.

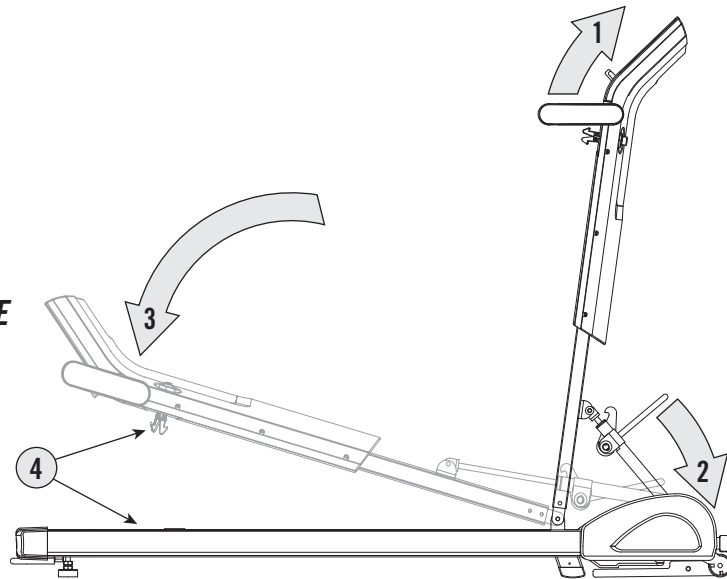

MOVING AND STORAGE



Our treadmills can be heavy. Use care and additional help if necessary when moving. Do not attempt to move or transport treadmill unless both the lock latches are secured. Failure to follow these instructions could result in injury.

MOVING / STORAGE

This treadmill has a pair of transport wheels built under the base frame. To move, make sure the treadmill is folded down and securely latched. Then, firmly grasp the lifting handlebar, lift the treadmill up and roll. This treadmill can be stored horizontally (under a bed) or vertically (against a wall).

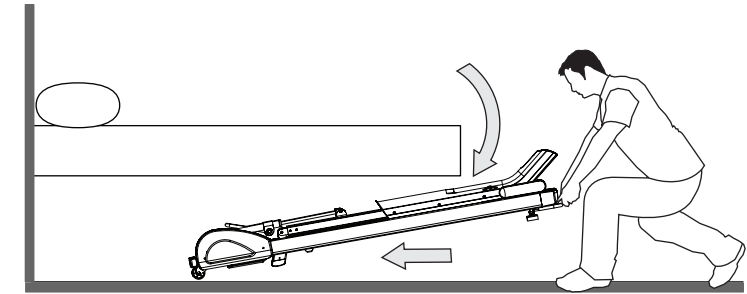

To store underneath a bed, firmly grasp the lifting bar and move the treadmill. Gently lower and push the treadmill under the bed. (See illustration above)

CAUTION:

To prevent damage to the treadmill, make sure the area has enough space to store the treadmill.

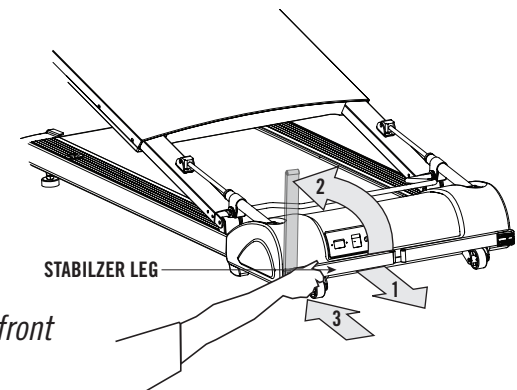

This treadmill is equipped with two **STABILIZER LEGS** on the front side. To store the treadmill vertically, follow these steps:

1. To stand the treadmill up, pull the **STABILIZER LEGS** outward.
2. Turn the **STABILIZER LEGS** so they face upward.
3. Push the **STABILIZER LEGS** back in to lock them in place.
4. Place the treadmill close to wall with the **STABILIZER LEGS** facing the wall. Carefully lift the treadmill up using the **LIFTING BAR**.
5. Pull the **STABILIZER BRACKET** upward.
6. Rotate the **STABILIZER BRACKET** down all the way to the floor. The **STABILIZER BRACKET** will automatically lock in place.
7. To put the treadmill back down, pull the **STABILIZER BRACKET** towards you and rotate it upward until it locks.
8. Follow the steps above in reverse order to completely put the treadmill back down.

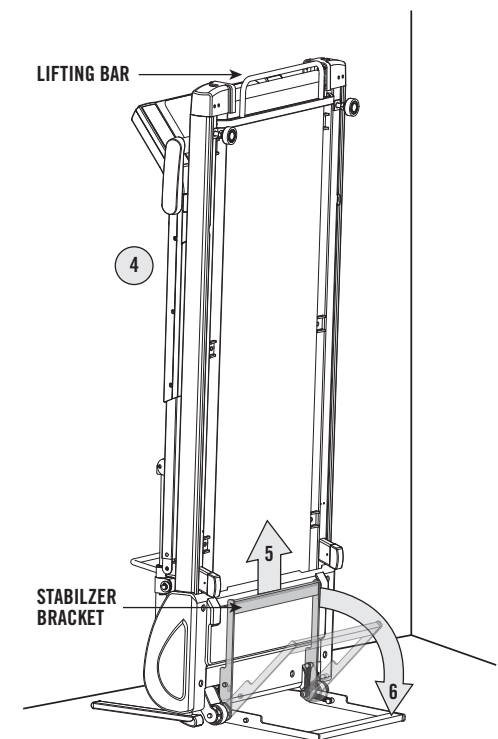

BEFORE YOU BEGIN

Your treadmill can be a tremendously effective tool for achieving your personal fitness goals. Regular use of your treadmill can improve the quality of your life in so many ways.

HERE ARE JUST A FEW OF THE HEALTH BENEFITS OF EXERCISE:

- Weight Loss
- A Healthier Heart
- Improved Muscle Tone
- Increased Daily Energy Levels

The key to reaping these benefits is to develop an exercise habit. Your new treadmill will help you eliminate obstacles that prevent you from exercising. Inclement weather and darkness won't interfere with your workout when you use your treadmill in the comfort of your home. This guide provides you with basic information for using and enjoying your new machine.

LOCATION OF THE TREADMILL

Place the treadmill on a level surface. There should be 6 feet of clearance behind the treadmill, 3 feet on each side and one foot in front for folding and the power cord. Do not place the treadmill in any area that will block any vent or air openings. The treadmill should not be located in a garage, covered patio, near water or outdoors.

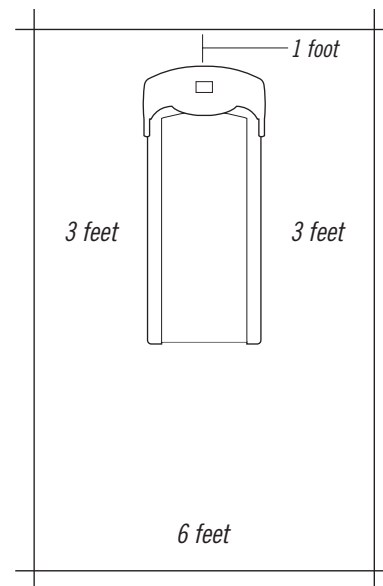

DO NOT STAND ON THE BELT

While you are preparing to use the treadmill, do not stand on the belt. Place your feet on the side rails before starting the treadmill. Start walking on the belt only after the belt has begun to move. Never start the treadmill at a fast running speed and attempt to jump on!

PROPER USAGE

Your treadmill is capable of reaching high speeds. Always start off using a slower speed and adjust the speed in small increments to reach a higher speed level. Never leave the treadmill unattended while it is running. When not in use, remove the safety key, turn the on/off switch to off and unplug the power cord. Make sure to follow the MAINTENANCE schedule located on page 22 in this manual. Keep your body and head facing forward. Do not attempt to turn around or look backwards while the treadmill is running. Stop your workout immediately if you feel pain, faint, dizzy or are short of breath.



Do not operate the treadmill if the power cord or plug is damaged. If the treadmill appears to not be working properly, do not use the treadmill.

SAFETY KEY

Your treadmill will not start unless the safety key is placed in position. Attach the clip end securely to your clothing. This safety key is designed to cut the power to the treadmill if you should fall. Check the operation of the safety key every 2 weeks.



NEVER USE THE TREADMILL WITHOUT SECURING THE SAFETY KEY CLIP TO YOUR CLOTHING. PULL ON THE SAFETY KEY CLIP FIRST TO MAKE SURE IT WILL NOT COME OFF YOUR CLOTHING.

TURN THE POWER ON

Make sure that your treadmill is properly connected to a power outlet. The ON/OFF switch is located next to the power cord. Flip this switch to the ON position, so that the switch is lit. You will hear a beep and the console will turn on.

TENSIONING THE RUNNING BELT

The running belt has been properly adjusted at the factory before it was shipped. At times the belt can move off-center during shipment.

CAUTION: Running belt should NOT be moving during tensioning. Over-tightening the running belt can cause excessive wear on the treadmill as well as its components. Never over-tighten the belt.

If you can feel a slipping sensation when running on the treadmill, the running belt must be tightened. In most cases, the belt has stretched from use, causing the belt to slip. This is a normal and common adjustment. To eliminate this slipping, **TURN THE TREADMILL OFF** and tension **BOTH THE REAR ROLLER BOLTS** using the supplied Allen wrench, turning them 1/4 TURN to the right as shown. Turn the treadmill on and check for slipping. Repeat if necessary, but **NEVER TURN** the roller bolts more than 1/4 turn at a time. Belt is properly tensioned when the slipping sensation is gone.

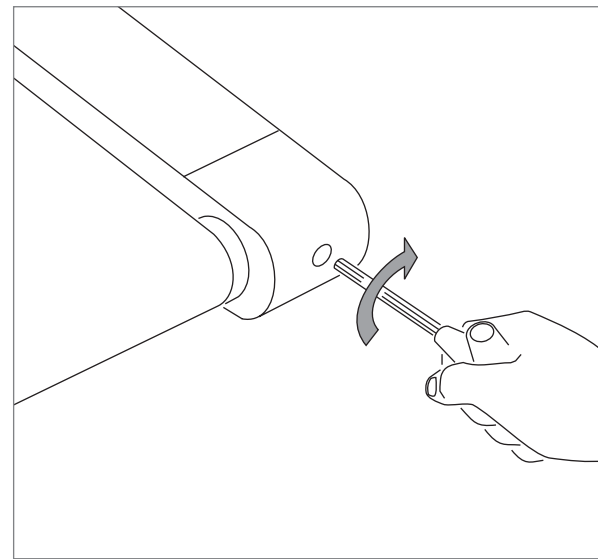
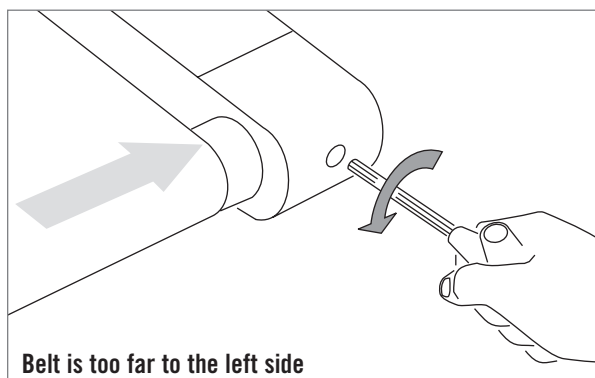
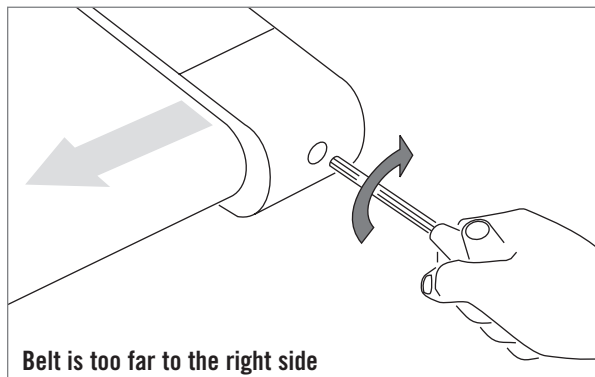

CENTERING THE RUNNING BELT

The running belt has been properly adjusted at the factory before it was shipped. At times the belt can move off-center during shipment. Before operating the treadmill, make sure the belt is centered and remains centered to maintain smooth operation.

CAUTION: Do not run belt faster than 1 mph while centering. Keep fingers, hair and clothing away from belt at all times.

If the running belt is too far to the right side: With the treadmill running at 1 mph, turn the right adjustment bolt clockwise 1/4 TURN at a time (using the supplied Allen wrench). Check the belt alignment. Allow belt to run a full cycle to gauge if more adjustment is needed. Repeat if necessary, until the belt remains centered during use.

If the running belt is too far to the left side: With the treadmill running at 1 mph, turn the right adjustment bolt counter-clockwise 1/4 TURN at a time (using the supplied Allen wrench). Check the belt alignment. Allow belt to run a full cycle to gauge if more adjustment is needed. Repeat if necessary, until the belt remains centered during use.

TREADMILL OPERATION

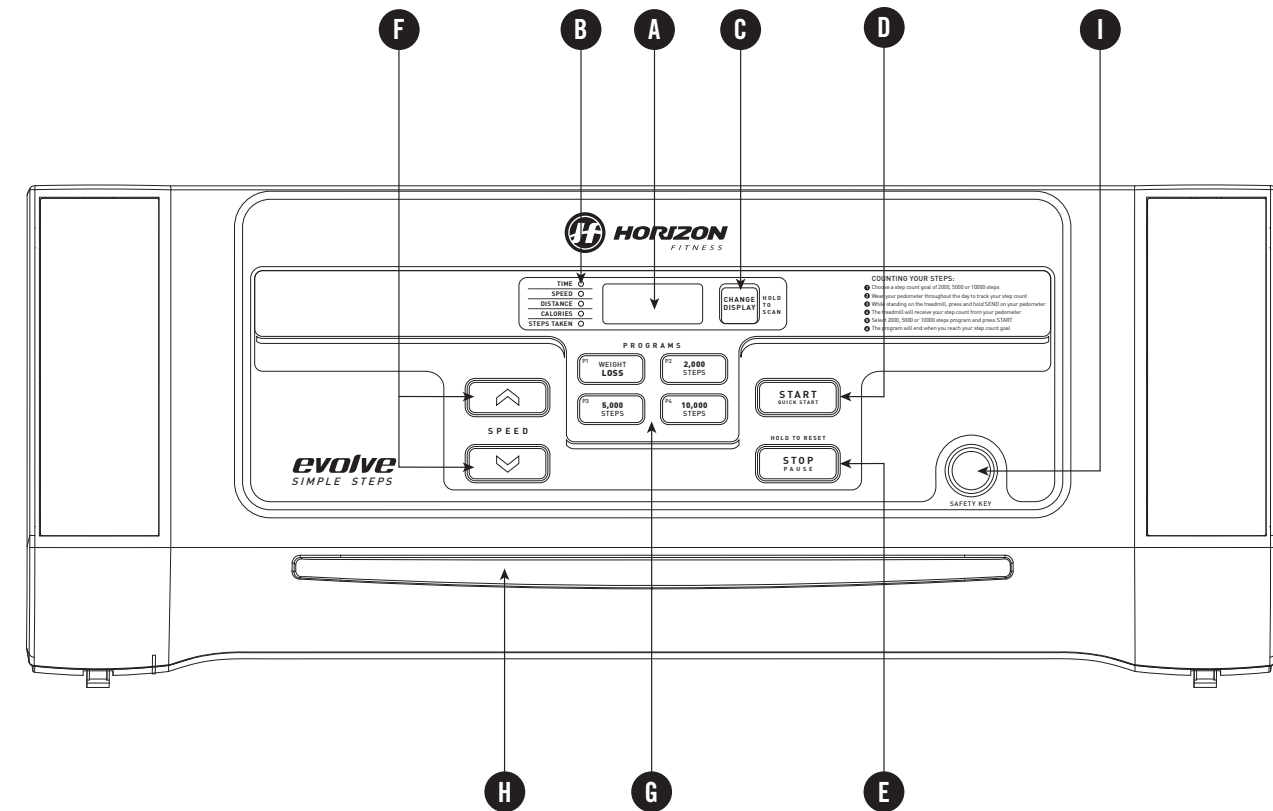

Note: There is a thin protective sheet of clear plastic on the overlay of the console that should be removed.

A) LCD DISPLAY: Time, Speed, Distance, Calories and Steps Taken.

B) FEEDBACK LEDS: Indicate what workout feedback is currently being displayed.

C) CHANGE DISPLAY BUTTON: Press to change the feedback on the LCD display. Hold for 2-3 seconds to scan.

D) START: Simply press to begin exercising or starts your program.

E) STOP/PAUSE: Press to pause/end your workout. Hold for 3 seconds to reset the treadmill.

F) SPEED ARROW KEYS: Used to adjust speed in small increments (1-6 mph in 0.1 mph increments).

G) PROGRAM KEYS: Used to select desired program.

H) SAFETY KEY POSITION: Enables treadmill when safety key is inserted.

I) READING RACK: Holds reading material.

MONITOR DISPLAY

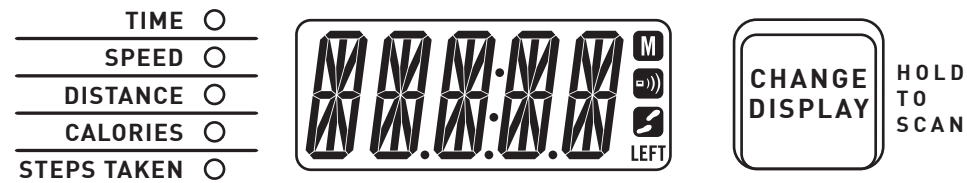

TIME • Shown as Minutes: Seconds. View the time remaining or the time elapsed in your workout.

SPEED • Shown as KPH or MPH. Indicates how fast the walking or jogging surface is moving.

DISTANCE • Shown as Kilometers or Miles. Indicates distance traveled during your workout.

CALORIES • Total Calories burned during your workout.

STEPS TAKEN • Total steps taken from the pedometer.

M - Manual mode

Ⓜ - Indicates Pedometer is transmitting steps to the treadmill.

S - Steps program is selected.

LEFT - Indicates number of steps left until goal is reached.

GETTING STARTED / SELECTING A PROGRAM

- 1) Check to make sure nothing will hinder the movement of the treadmill.
- 2) Plug in the power cord and turn the treadmill ON.
- 3) Stand on the side rails of the treadmill.
- 4) Attach the safety key clip to part of your clothing.
- 5) Insert the safety key into the safety keyhole in the console.
- 6) You have two options to start your workout:

A) QUICK START UP

Simply press the **START** key to begin working out. OR...

B) SELECT A PROGRAM

Select a **PROGRAM** using the **PROGRAM KEYS**.

Press **START** to begin.

FINISHING YOUR WORKOUT

When your workout is complete, the **LCD DISPLAY** will display **STOP**.

CLEAR CURRENT SELECTION

To clear the current program selection or screen, hold the **STOP** button for 3 seconds.

SCAN VIEWING SCREENS

To have the display screen rotate continuously (Time, Speed, Distance, Calories, Steps Taken and Steps Left), hold the **CHANGE DISPLAY** button for 3 seconds. Press **CHANGE DISPLAY** again to turn off scan feature.

Note: Steps Left are only displayed during Steps program.

PROGRAM INFORMATION

MANUAL MODE

Is only selected by pressing **QUICK START**.

Allows "On The Fly" manual speed changes. Time will count up from 0:00.

PROGRAM 1: WEIGHT LOSS

Keeps user in their optimal fat burning zone. This is a 30 minute program.

WEIGHT LOSS PROGRAM SEGMENTS

(All segments including warm up and cool down last 60 seconds. Segments repeat.)

	2:00		2:00		Segments 1-12												2:00		2:00	
PROGRAM SEGMENT	WARM UP				1	2	3	4	5	6	7	8	9	10	11	12	COOL DOWN			
SPEED (MPH)	2	2	2	3	2	3	3	4	4	3	3	4	4	3	3	4	3	3	2	2

USING STEP PROGRAMS

Your treadmill comes with a wireless pedometer and programming specifically designed to help you reach your daily step goals. In order to reach your goals, it is recommended that you follow these steps.

- Choose a daily step count goal of 2,000, 5,000 or 10,000 steps.
- Wear your wireless pedometer throughout the day to record your steps.
- At the end of the day, transmit your accumulated steps to the treadmill.
- The treadmill will automatically adjust your workout to account for the steps you have accumulated. For example... if you have a goal of walking 5,000 steps per day and you log 1,000 steps throughout the day, the treadmill will automatically adjust your step count so you will only have to walk 4,000 more steps to reach your goal.

NOTE: If pedometer steps are not uploaded the 2,000, 5,000 and 10,000 step programs will end at 60 minutes.

2000 P2: 2,000 STEPS

Step-based program. Transmits steps taken from your pedometer and continues until program goal is reached. Allows "On The Fly" manual speed changes. Time will count up from 0:00.

NOTE: 2,000 steps = 1.0 mile based on the average stride length. Actual distance may vary.

5000 P3: 5,000 STEPS

Step-based program. Transmits steps taken from your pedometer and continues until program goal is reached. Allows "On The Fly" manual speed changes. Time will count up from 0:00.

NOTE: 5,000 steps = 2.5 miles based on the average stride length. Actual distance may vary.

10000 P4: 10,000 STEPS

Step-based program. Transmits steps taken from your pedometer and continues until program goal is reached. Allows "On The Fly" manual speed changes. Time will count up from 0:00.

NOTE: 10,000 steps = 5 miles based on the average stride length. Actual distance may vary.

WIRELESS PEDOMETER INSTRUCTIONS

POSITIONING PEDOMETER

Attach the pedometer to your belt, skirt, waistline, etc, with the clip located on the back of the pedometer. Do NOT place the pedometer in line with the center of your body. Instead position the pedometer to the left or right of the center of your body to ensure proper step count during your workout. Be sure to attach the pedometer horizontally and securely enough that it will not become dislodged during workout.

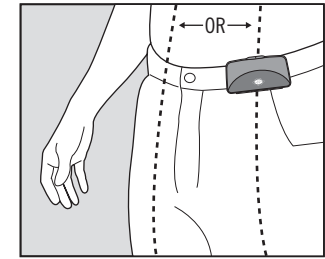

TO COUNT YOUR STEPS



POWER ON/DISPLAY STEP COUNT:

- Press **Send**.
- Displays step count accumulated since the unit was last reset.



DISPLAY ACCUMULATED TIME

- Press **Send** again.
- Displays time accumulated since the unit was last reset.
- Shown as hours-minutes



RETURN TO STEP COUNT

- The display will automatically return to step count after 5 seconds.



RESET STEP COUNT AND ACCUMULATED TIME

- Hold **Clear** for 2 seconds.



TO TRANSMIT YOUR STEPS



TRANSMIT STEP COUNT

- Hold **Send** for 2 seconds while "Upload Steps" is scrolling.
- The display will read, "Send" while the transmission takes place.
- The step count will automatically update during the workout.
- The program will end when the step count goal is reached.

NOTE: Transmission can take up to 15 seconds.
The pedometer may transmit in either step count mode or accumulated time mode.

NOTE: Step count can be loaded at any time before or after **START** is pressed.

WIRELESS PEDOMETER INSTRUCTIONS

CUSTOMIZING THE SETTINGS

- **TO ENTER SETTINGS MODE:** While the display shows Step Count, press and hold **Send** and **Clear** for 3 seconds.
- **TO SCROLL THROUGH MODES:** Press **Send** to advance a mode and **Clear** to go back a mode.
- **TO ENTER MODE:** Press and hold **Send** for 3 seconds to enter a chosen mode.
- **TO SCROLL THROUGH OPTIONS:** Press **Send** to advance a setting and **Clear** to go back a setting.
- **TO SAVE OPTION:** Press and hold **Send** for 3 seconds to save setting and exit mode.
- **TO EXIT OPTION (WITHOUT SAVING):** Press and hold **Clear** for 3 seconds to exit the mode without saving changes.
- **TO EXIT SETTINGS MODE:** Press and hold **Clear** for 3 seconds.

P-0: SOFTWARE VERSION - Cannot be changed.

P-1: DISPLAY BRIGHTNESS - There are eight brightness settings to choose from.

P-2: STEP COUNT UPDATE (STEPS) - Adjusts how often (in steps) the pedometer will transmit to the treadmill. The pedometer's default setting should not be adjusted as it is preset for optimal battery longevity.

P-3: STEP COUNT UPDATE (SECONDS) - Adjusts how often (in seconds) the pedometer will transmit to the treadmill. The pedometer's default setting should not be adjusted as it is preset for optimal battery longevity.

P-4: SLEEP MODE - The display back light will automatically turn off if there is no activity for 30 seconds. The pedometer's default setting should not be adjusted as it is preset for optimal battery longevity.

P-5: SENSITIVITY SETTING - There are three sensitivity settings to choose from. Use the following guide to customize your sensitivity needs:

- L1 = Low for heavy running/walking
- L2 = Medium for light jogging or medium walking (default)
- L3 = High for light walking

TROUBLESHOOTING

BATTERY REPLACEMENT

The battery in your pedometer can be expected to last six months for someone who walks 10,000 steps per day. Results may vary depending on usage. Your pedometer uses one (1) Lithium CR1225 battery. Should your display become faint or the transmitter signal only picks up at a very short distance, it may be time to replace the battery.

Note: Battery replacement is the responsibility of the customer and is not covered under Horizon Fitness' Limited Home Use Warranty.

NO DISPLAY

- The LCD display is designed to be used in temperatures between 32 to 104 degrees Fahrenheit (0-40 degrees Centigrade). If the pedometer is being used outside of this range, return to room temperature to restore operation.
- Avoid placing the LCD in direct sunlight for long periods of time. Return to room temperature to restore operation.
- The pedometer may be in Sleep Mode. Press the SEND button to turn on pedometer.
- The battery needs to be replaced. Your pedometer uses one (1) Lithium CR1225 battery.

ERRATIC OR INCONSISTENT DISPLAY

- The pedometer may not be positioned correctly on your body. See 'Positioning Pedometer' in Section 1 for details.
- The battery needs to be replaced. Your pedometer uses one (1) Lithium CR1225 battery.
- If the treadmill display is erratic: Check your exercise environment for sources of interference such as fluorescent lights, computers, underground fencing, home security systems or appliances containing large motors. These items may cause interference between the pedometer and the receiver on the treadmill.

INACCURATE STEP COUNT

- For the most accurate step count readings, you must walk at a speed over 2.0 mph. The average walking speed is 2-4 mph.
- If you believe your step count is inaccurate, do the following: Walk and count 100 steps. Compare your count to the pedometer's. If the pedometer's count is less than yours, increase the sensitivity setting. If the pedometer's count is more than yours, decrease the sensitivity setting. (See Settings, P-5 to change the sensitivity setting.)

CONDITIONING GUIDELINES

ALWAYS CONSULT YOUR PHYSICIAN BEFORE BEGINNING AN EXERCISE PROGRAM.

HOW OFTEN? (Frequency of Workouts)

The American Heart Association recommends that you exercise at least 3 to 4 days per week to maintain cardiovascular fitness. If you have other goals such as weight or fat loss, you will achieve your goal faster with more frequent exercise. Whether it's 3 days or 6 days, remember that your ultimate goal should be to make exercise a lifetime habit. Many people are successful staying with a fitness program if they set aside a specific time of day to exercise. It doesn't matter whether it's in the morning before breakfast, during lunch hour or while watching the evening news. What's more important is that it's a time that allows you to keep a schedule, and a time when you won't be interrupted. To be successful with your fitness program, you have to make it a priority in your life. So decide on a time, pull out your day planner and pencil in your exercise times for the next month!

HOW LONG? (Duration of Workouts)

For aerobic exercise benefits, it's recommended that you exercise for 24 to 60 minutes per session. But start slowly and gradually increase your exercise times. If you've been sedentary during the past year, it may be a good idea to keep your exercise times to as little as five minutes initially. Your body will need time to adjust to the new activity. If your goal is weight loss, a longer exercise session at lower intensities has been found to be most effective. A workout time of 48 minutes or more is recommended for best weight loss results.

HOW HARD? (Intensity of Workouts)

How hard you workout is also determined by your goals. If you use your treadmill to prepare for a 5K run, you will probably work out at a higher intensity than if your goal is general fitness. Regardless of your long-term goals, always begin an exercise program at low intensity. Aerobic exercise does not have to be painful to be beneficial! There are two ways to measure your exercise intensity. The first is by monitoring your heart rate (using a wireless chest transmitter and receiver - sold separately), and the second is by evaluating your perceived exertion level (this is simpler than it sounds!).

PERCEIVED EXERTION LEVEL

A simple way to gauge your exercise intensity is to evaluate your perceived exertion level. While exercising, if you are too winded to maintain a conversation without gasping, you are working out too hard. A good rule of thumb is to work to the point of exhilaration, not exhaustion. If you cannot catch your breath, it's time to slow down. Always be aware of these warning signs of overexertion.

TARGET HEART RATE ZONE CHART

What is Target Heart Rate Zone?

Target Heart Rate Zone tells you the number of times per minute your heart needs to beat to achieve a desired workout effect. It is represented as a percentage of the maximum number of times your heart can beat per minute. Target Zone will vary for each individual, depending on age, current level of conditioning, and personal fitness goals. The American Heart Association recommends working out at a Target Heart Rate Zone of between 60% and 75% of your maximum heart rate. A beginner will want to workout in the 60% range while a more experienced exerciser will want to workout in the 70-75% range. See chart for reference.

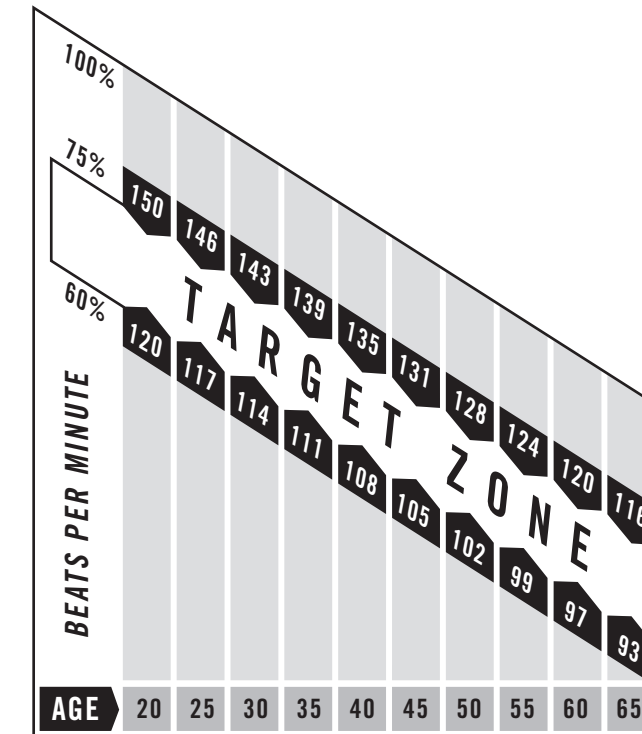

EXAMPLE:

For a 42-year-old user: Find age along the bottom of the chart (round to 40), follow age column up to the target zone bar. Results: 60% of maximum Heart Rate = 108 Beats Per Minute, 75% of maximum Heart Rate = 135 Beat Per Minute.

ALWAYS CONSULT YOUR PHYSICIAN BEFORE BEGINNING AN EXERCISE PROGRAM.

TIPS ✓**STRETCHING****STRETCH FIRST**

Before using your product, it is best to take a few minutes doing a few gentle stretching exercises. Stretching prior to exercise will improve flexibility and reduce chances of exercise related injury. Ease into each of these stretches with a slow gentle motion. Do not stretch to the point of pain. Make sure not to bounce while doing these stretches.

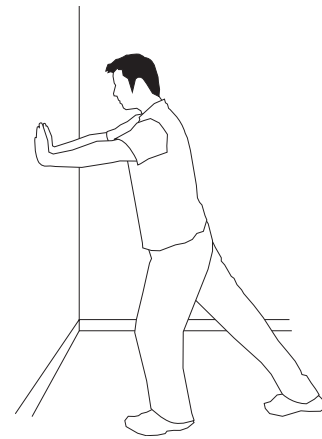
**1. STANDING CALF MUSCLE STRETCH**

Stand near a wall with the toes of your left foot about 18" from the wall, and the right foot about 12" behind the other foot. Lean forward, pushing against the wall with your palms. Keep your heels flat and hold this position for a count of 15 seconds. Make sure that you do not bounce while stretching. Repeat on the other side.

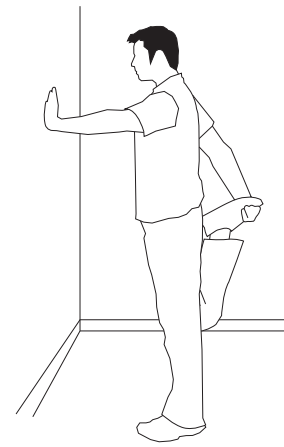
**2. STANDING QUADRICEP STRETCH**

Using a wall to provide balance, grasp your left ankle with your left hand and hold your foot against the back of your thigh for 15 seconds. Repeat with your right ankle and hand.

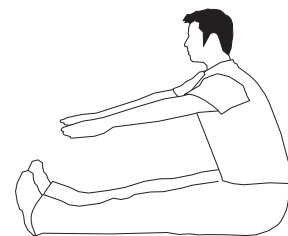
**3. SITTING HAMSTRING & LOWER BACK MUSCLE STRETCH**

Sit on the floor with your legs together and straight out in front of you. Do not lock your knees. Extend your fingers towards your toes and hold for a count of 15 seconds. Make sure that you do not bounce while stretching. Sit upright again. Repeat one time.

TIPS ✓**THE IMPORTANCE OF WARM-UP & COOL-DOWN****WARM-UP**

The first 2 to 5 minutes of a workout should be devoted to warming up. The warm-up will limber your muscles and prepare them for more strenuous exercise. Make sure that you warm-up on your product at a slow pace. The warm-up should gradually bring your heart rate into your Target Heart Rate Zone.

COOL DOWN

Never stop exercising suddenly! A cool-down period of 3-5 minutes allows your heart to readjust to the decreased demand. Make sure that your cool-down period consists of a very slow pace to allow your heart rate to lower. After the cool-down, repeat the stretching exercises listed above to loosen and relax your muscles.

TIPS ✓**ACHIEVING YOUR FITNESS GOALS**

An important step in developing a long-term fitness program is to determine your goals. Is your primary goal for exercising to lose weight? Improve muscle? Reduce stress? Prepare for the spring racing schedule? Knowing what your goals are will help you develop a more successful exercise program. Below are some common exercise goals:

- Weight Loss - lower intensity, longer duration workouts
- Improve Body Shape and Tone - interval workouts, alternate between high and low intensities
- Increased Energy Level - more frequent daily workouts
- Improved Sports Performance - high-intensity workouts
- Improved Cardiovascular Endurance - moderate intensity, longer duration workouts

If possible try to define your personal goals in precise, measurable terms, and then put your goals in writing. The more specific you can be, the easier it will be to track your progress. If your goals are long term, divide them up into monthly and weekly segments. Longer term goals can lose some of the immediate motivation benefits. Short-term goals are easier to achieve. Your console provides you with several readouts that can be used to record your progress. You can track Distance, Calories or Time.

TROUBLESHOOTING

COMMON PRODUCT QUESTIONS

ARE THE SOUNDS MY TREADMILL MAKES NORMAL?

All treadmills make a certain type of thumping noise due to the belt riding over the rollers, especially new treadmills. This noise will diminish over time, although may not totally go away. Over time, the belt will stretch, causing the belt to ride smoother over the rollers.

WHY IS THE TREADMILL I PURCHASED LOUDER THAN THE ONE AT THE STORE?

All fitness products seem quieter in a large store showroom because there is generally more background noise than in your home. Also, there will be less reverberation on a carpeted concrete floor than on a wood overlay floor. Sometimes a heavy rubber mat will help reduce reverberation through the floor. If a fitness product is placed close to a wall, there will be more reflected noise.

TROUBLESHOOTING - TREADMILL

Your treadmill is designed to be reliable and easy to use. However, if you experience a problem, please reference the troubleshooting guide listed below.

PROBLEM: The console does not turn on and/or the belt does not move.

SOLUTION: Verify the following:

DOES THE RED LIGHT ON THE ON/OFF SWITCH LIGHT UP?

IF YES:

- Make sure treadmill is turned on.
- Double check that all connections are secure, especially the console cable. Unplug and reconnect the console cable to verify.
- Make sure the console cable is not pinched or damaged in any way.
- Turn the power off, unplug the power cable and wait 60 seconds. Remove motor cover. Wait until all red LED lights have gone off on the motor control board before proceeding. Next, verify that none of the wires connected to the lower board are loose or disconnected.

IF NO:

- Verify that the outlet the machine is plugged into is functional. Double check that the breaker has not tripped, it is on a dedicated 15 amp circuit, it is not on a GFCI-equipped outlet, and it is not plugged into a power strip/surge protector or extension cord.
- The power cord is not pinched or damaged and is properly plugged into the outlet AND the machine.
- The power switch is turned to the ON position.

PROBLEM: The treadmill circuit breaker trips during a workout.

SOLUTION: Verify the following:

- Make sure the treadmill is plugged into a dedicated 15 amp circuit.
- Verify that you do not have the machine on an extension cord or surge protector.
- Confirm that the machine is not plugged into a GFCI-equipped outlet or on a circuit that has a GFCI-equipped outlet on it.

PROBLEM: The running belt does not stay centered during a workout.

SOLUTION: Verify the following:

- Make sure the treadmill is on a level surface.
- Verify that the belt is properly tightened and centered (Refer to the Adjustment section for detailed directions).

If the above troubleshooting section does not remedy the problem, discontinue use and turn the power off.

PLEASE CALL CUSTOMER TECH SUPPORT AT THE NUMBER ON THE BACK PANEL.

The following information may be asked of you when you call. Please have these items readily available:

- Model Name
- Serial Number
- Date of Purchase (receipt or credit card statement)

In order for Customer Tech Support to service your treadmill they may need to ask detailed questions about the symptoms that are occurring. Some troubleshooting questions that may be asked are:

- How long has this problem been occurring?
- Does this problem occur with every use? With every user?
- If you are hearing a noise, does it come from the front or the back? What kind of noise is it (thumping, grinding, squeaking, chirping etc.)?
- Has the machine been lubricated and maintained per the maintenance schedule?

Answering these and other questions will give the technicians the ability to send proper replacement parts and the service necessary to get you and your Horizon Fitness treadmill running again!

MAINTENANCE

Cleanliness of your treadmill and its operation environment will keep maintenance problems and service calls to a minimum. For this reason, we recommend that the following preventive maintenance schedule be followed.

AFTER EACH USE (DAILY)

Clean and inspect, following these steps:

- Turn off the treadmill with the on/off switch, then unplug the power cord at the wall outlet.
- Wipe down the running belt, deck, motor cover, and console casing with a damp cloth. Never use solvents, as they can cause damage to the treadmill.
- Inspect the power cord. If the power cord is damaged, contact Horizon Fitness.
- Make sure the power cord is not underneath the treadmill or in any other area where it can become pinched or cut.
- Check the tension and alignment of the running belt. Make sure that the treadmill belt will not damage any other components on the treadmill by being misaligned.

EVERY WEEK

Clean underneath the treadmill, following these steps:

- Turn off the treadmill with the on/off switch, then unplug the power cord at the wall outlet.
- Fold the treadmill into the upright position, making sure that the lock latch is secure.
- Move the treadmill to a remote location.
- Wipe or vacuum any dust particles or other objects that may have accumulated underneath the treadmill.
- Return the treadmill to its previous position.

EVERY MONTH - IMPORTANT!

- Turn off the treadmill with the on/off switch, then unplug the power cord at the wall outlet.
- Inspect all assembly bolts of the machine for proper tightness.
- Turn off the treadmill and wait 60 seconds.
- Remove the motor cover. Wait until ALL LCDs turn off.
- Clean the motor and lower board area to eliminate any lint or dust particles that may have accumulated. Failure to do so may result in premature failure of key electrical components.
- Vacuum and wipe down the belt with a damp cloth. Vacuum any black/white particles that may accumulate around the unit. These particles may accumulate from normal treadmill use.

EVERY 6 MONTHS OR 150 MILES

It is necessary to lubricate your treadmill running deck every six months or 150 miles to maintain optimal performance. Your treadmill came with a bottle of lubricant which can be used for two applications. If you need lubricant, contact Horizon Fitness. Only use lubricant provided by Horizon Fitness.

- Turn off the treadmill with the on/off switch, then unplug the power cord at the wall outlet.
- Loosen both the rear roller bolts. (For best results, place two removable marks on both sides of the frame and note roller position). Once the belt is loosened, take the bottle of lubricant and apply it to the entire top surface of the running deck. Tighten both rear roller bolts (matching up the marks for proper position) to original position. After you have applied lubricant, plug in the power cord, insert the safety key, start the treadmill and walk on the belt for two minutes to spread the lubricant.

Please contact Horizon Fitness with questions about applying lubricant to your treadmill.

LUBRICATION

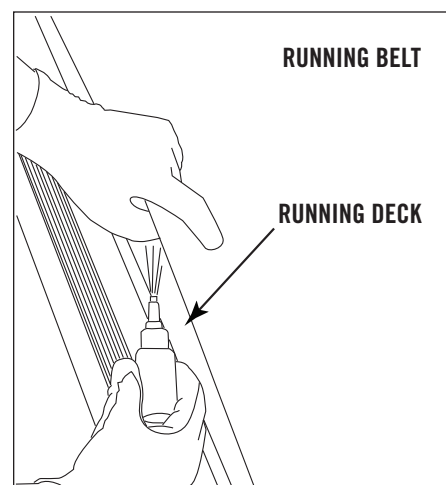

LIMITED HOME-USE WARRANTY

Weight Capacity = 114 KG / 250 LBS

FRAME • 10 YEARS

Horizon Fitness warrants the frame against defects in workmanship and materials for a period of ten years from the date of purchase, so long as the device remains in the possession of the original owner. (The frame is defined as the welded metal base of the unit and does not include any parts that can be removed.)

MOTOR • 5 YEARS

Horizon Fitness warrants the motor against defects in workmanship and materials for a period of five years from the date of purchase, so long as the device remains in the possession of the original owner.

ELECTRONICS & PARTS • 1 YEAR

Horizon Fitness warrants the electronic components, finish and all original parts for a period of 1 year from the date of original purchase, so long as the device remains in the possession of the original owner.

LABOR • 1 YEAR

Horizon Fitness shall cover the labor cost for the repair of the device for a period of 1 year from the date of original purchase, so long as the device remains in the possession of the original owner.

EXCLUSIONS AND LIMITATIONS

Who IS covered:

- The original owner and is not transferable.

What IS covered:

- Repair or replacement of a defective motor, electronic component, or defective part and is the sole remedy of the warranty.

What IS NOT covered:

- Normal wear and tear, improper assembly or maintenance, or installation of parts or accessories not originally intended or compatible with the equipment as sold.
- Damage or failure due to accident, abuse, corrosion, discoloration of paint or plastic, neglect, theft, vandalism, fire, flood, wind, lightning, freezing, or other natural disasters of any kind, power reduction, fluctuation or failure from whatever cause, unusual atmospheric conditions, collision, introduction of foreign objects into the covered unit, or modifications that are unauthorized or not recommended by Horizon Fitness.
- Incidental or consequential damages. Horizon Fitness is not responsible or liable for indirect, special or consequential damages, economic loss, loss of property, or profits, loss of enjoyment or use, or other consequential damages of whatsoever nature in connection with the purchase, use, repair or maintenance of the equipment.
- Equipment used for commercial purposes or any use other than a single family or Household, unless endorsed by Horizon Fitness for coverage.
- Equipment owned or operated outside the US and Canada.
- Delivery, assembly, installation, setup for original or replacement units or labor or other costs associated with removal or replacement of the covered unit.
- Any attempt to repair this equipment creates a risk of injury. Horizon Fitness is not responsible or liable for any damage, loss or liability arising from any personal injury incurred during the course of, or as a result of any repair or attempted repair of your fitness equipment by other than an authorized service technician. All repairs attempted by you on your fitness equipment are undertaken AT YOUR OWN RISK and Horizon Fitness shall have no liability for any injury to the person or property arising from such repairs.

SERVICE/RETURNS

- In-home service is available within 150 miles of the nearest authorized repair center (Mileage beyond 150 miles from an authorized service center is the responsibility of the consumer).
- All returns must be pre-authorized by Horizon Fitness.
- Horizon Fitness' obligation under this warranty is limited to replacing or repairing, at Horizon Fitness' option, the same or comparable model at one of its authorized service centers.
- A Horizon Fitness authorized service center must receive all equipment for which a warranty claim is made. This equipment must be received with all freight and other transportation charges prepaid, accompanied by sufficient proof of purchase.
- Replacement units, parts and electronic components reconditioned to As-new Condition by Horizon Fitness or its vendors may sometimes be supplied as warranty replacement and constitute fulfillment of warranty terms.
- This warranty gives you specific legal rights, and your rights may vary from state to state.

CUSTOMER TECH SUPPORT

For fast and friendly service, please contact one of our trained customer technicians via phone, email or our website.

Customer Tech Support Hotline: 1-800-244-4192

Email: comments@horizonfitness.com

Website: www.horizonfitness.com

Every employee at Horizon Fitness takes pride in providing you with a high quality product. We want to know if you have a problem and we want to have an opportunity to correct it for you.

NOTE: *Please read the TROUBLESHOOTING section before contacting Customer Tech Support. To receive additional product information, visit us at www.horizonfitness.com*



HORIZON
FITNESS

1620 Landmark Drive,
Cottage Grove WI, 53527
Tel: 1.800.244.4192
Fax: 608.839.1260