

# Running Belt & Deck Replacement 2007

## Tools Required

- T wrench
- 6mm Allen Wrench
- 5mm Allen Wrench
- 13" Socket or Open Wrench
- Phillips Head Screw Driver
- Tape

## Procedure

- 1 Turn off power to the treadmill and unplug the power cord from the wall outlet.
- 2 Remove motor cover, rear roller end caps and guide rails. **(F1 & F2)**
- 3 Using a piece of tape, mark the placement of the rear roller tension bolts. **(F3)**
- 4 Remove bolts and rear roller. **(F4)**

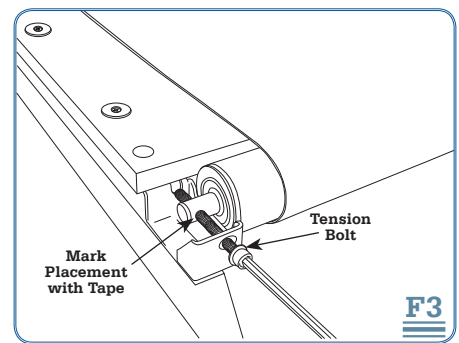
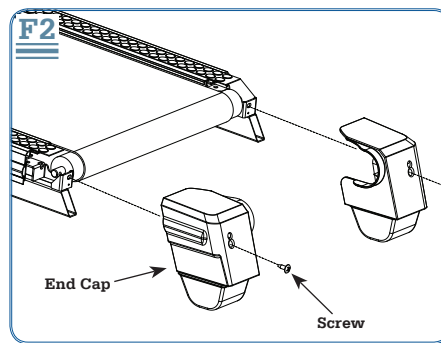
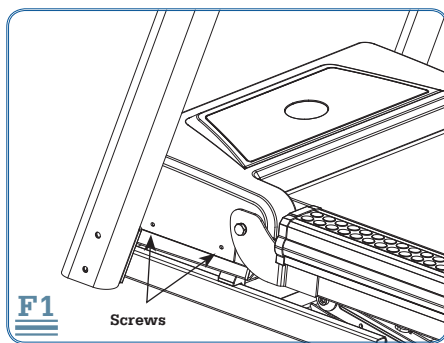

- 5 Using a piece of tape, mark the placement of the front roller tension bolts.
- 6 Remove the front right tension bolt. **(F5)**
- 7 Remove the RPM sensor. **(F5)**
- 8 Release the drive belt from the front roller and remove the front roller. **(F5)**
- 9 Remove deck bolts. **(F6)**

**IMPORTANT** If you are only replacing the running belt, it is not necessary to remove all of the deck bolts. Remove the right side bolts instead and slide the running belt out.

- 10 Lift the deck and slide the running belt off of the right hand side of the deck.

**WARNING** With the weight of the deck removed, the frame may pop up. Hold the frame down when you remove the deck. **WARNING**

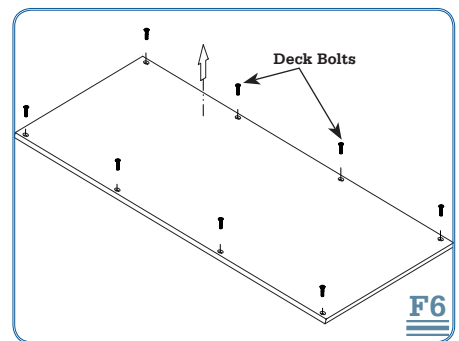
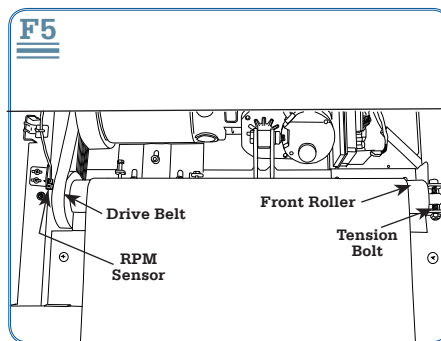
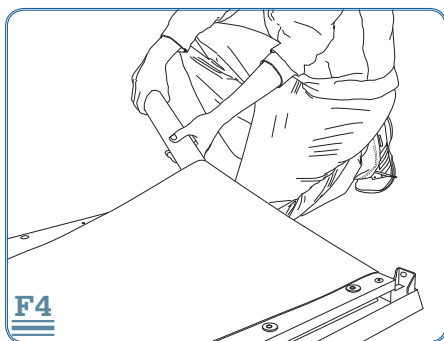

### Continued

- 11 Place the new Deck on the Frame. Reattach the left side bolts. (F6)
- 12 Mark placement of Bolt on Motor Bracket. (F7)
- 13 Loosen the top bolt and horizontal bolts on motor bracket until drive belt is loose.
- 14 Slide the front roller into place and put the drive belt on the front roller. (F5)
- 15 Tighten the bolts on the motor bracket using the guides from **step 12**.

**Note: Make sure the drive belt stays straight and in place on the roller and flywheel.**

- 16 Set rear roller into place. Insert bolt on left side. (F8)
- 17 Holding the deck up, slide the running belt onto the deck, insert the front roller first, then insert the rear roller under the running belt. Reaching through the running belt, grab a hold of the deck and slide into place.
- 18 Reattach the deck bolts. (F6)

**Note: It may be necessary to pull the frame in order to get the holes lined up.**

- 19 Reattach the front roller to the frame using the guides from **step 5**. (F5)
- 20 Reinsert and attach right rear roller. Do not tighten all the way.
- 21 Distribute two bottles of silicone oil on the deck. (**Reference Owners Manual**)
- 22 Adjust running belt to appropriate tension using the guides from **step 3**.
- 23 Reattach the RPM sensor. (F5)
- 24 Plug unit in, turn on and run for approximately 15 minutes to evenly distribute the silicone oil and verify running belt tension and alignment.

