

Console Cable Replacement

For 1.2 Only

Tools required:

- Phillips Screwdriver
- 5mm Allen Wrench
- String or Electrical Tape

Procedure:

1. Turn off power to the treadmill and unplug the power cord from the wall outlet.
2. Remove motor cover.
3. Disconnect the console cable from the lower board.
4. Remove back of console exposing upper board (Figure 1) and disconnect console cable.
5. Detach console mast side covers by removing Screws AA (Figure 2).
6. Remove Bolts B and Nuts C, allowing the console to fold forward (Figure 3).

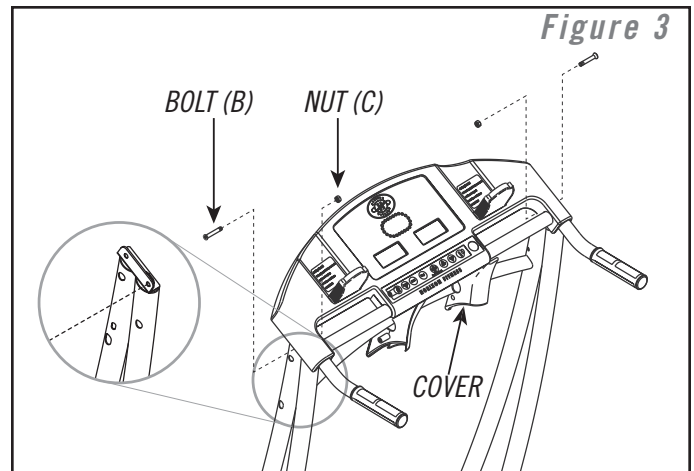
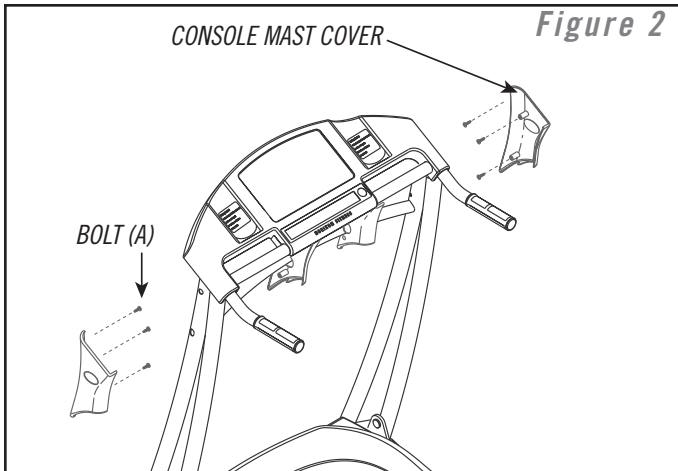
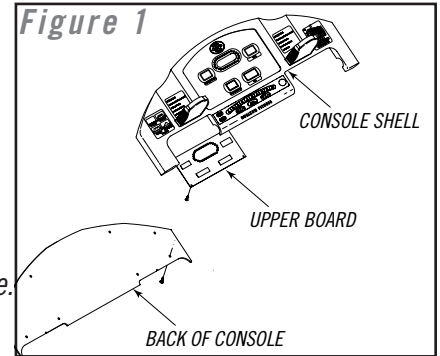

7. Attach console cable to the bottom of old console cable using string or electrical tape. (figure 4)

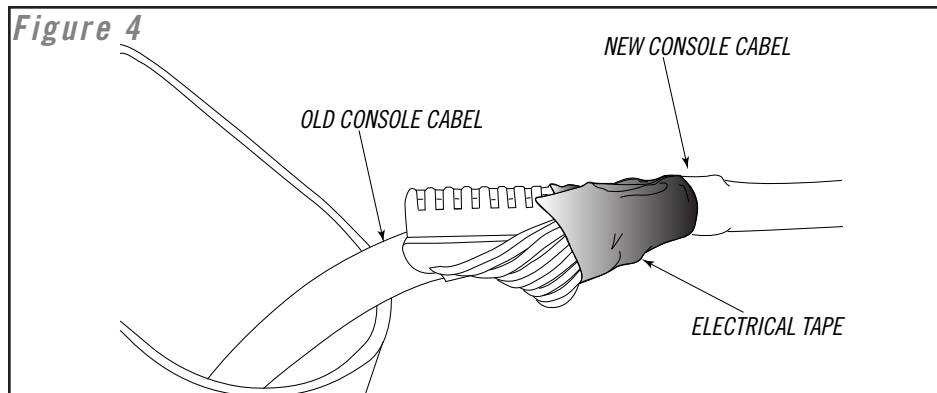

8. Pull the old cable from the top until the new cable comes out.
9. Reconnect the console cable to the upper and lower boards.
10. Reinstall the motor cover and back of console.