

# Adjusting the Magnetic Brake

(EX-22, EX-33, EX-44, CSE 3.5, 4.5, EG5, 1.2E, 3.2E, 4.2E)

## Tools Required:

- Phillips Screwdriver
- 8mm, 13mm, 17mm Socket and Combination Wrenches
- 5mm Allen Wrench
- Crank Puller

## Procedure:

1. 1.2E only-Adjust tension knob to highest setting.
2. Turn on unit and Press start.
3. Set resistance highest level and power off unit.
4. Remove side covers. (Reference side cover replacement in Parts Replacement section.)
4. Loosen the short nut (A), and adjust the long nut (B) clockwise to reduce the brake resistance and counterclockwise to increase the brake resistance.



The correct position for the flywheel/brake assembly is 1 -2mm from the flywheel at the highest resistance level.

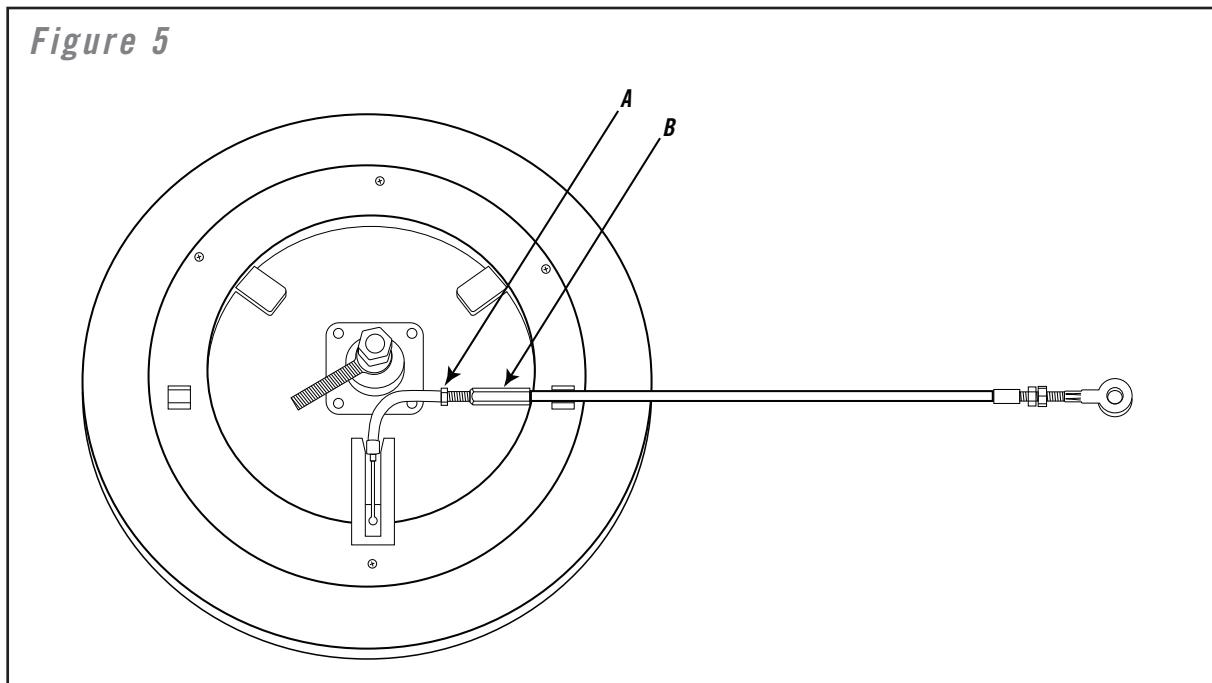

# Adjusting the Magnetic Brake (2.2E)

## Tools Required:

- Phillips Screwdriver
- 12mm, 13mm, 14mm, 17mm Socket and Combination Wrenches
- 5mm Allen Wrench
- Crank Puller

## Procedure:

1. Turn on unit and Press start.
2. Set resistance highest level and power off unit.
3. Remove crank disk and side covers. (Reference Crank Disk/Side Cover/Crank Arm Replacement in Parts Replacement section.)
4. Adjust the nut on the magnetic brake spring clockwise to reduce the brake resistance and counterclockwise to increase the brake resistance.



The correct position for the flywheel/brake assembly is 2-3mm from the flywheel at the highest resistance level.

5. It may be necessary to also adjust the top half of the magnetic brake. To do this, loosen the two 5mm bolts that attach the magnetic brake to the frame. Adjust the position of the magnetic brake closer or further from the flywheel.

Figure 6

